



KT-EMRG-LED-5-500-EN /DF

CONSTANT WATTAGE LED EMERGENCY BACK-UP



DESCRIPTION

LED Emergency Back-Up Driver | Dual Flex Conduit | 5W Output | 120-277V Input

DRIVER TYPE: Constant Wattage LED Emergency

MAX. OUTPUT POWER: 5W

INPUT VOLTAGE: 120-277Vac $\pm 10\%$

OUTPUT VOLTAGE: 20~54Vdc

OUTPUT CURRENT: 250mA-100mA

WARRANTY: 5 Years



PRODUCT FEATURES

- Drives LED Loads at 5W (Nominal) for a Minimum of 90 Minutes
- Meets FCC Part 15 (Class B) Consumer Limits
- Short Circuit Overload and Open Load Protection
- Type 1 Outdoor, Suitable for Dry and Damp Locations
- Evaluated to UL 924 Standards
- Operating Temperature: 32°F/0°C to 122°F/50°C
- Input Frequency: 50/60 Hz
- Test Switch/ Charging Indicator Light and Wall Plate Included
- Battery Pack with Quick Connect; NiCd
- Battery Capacity: 1200mAh

SPECIFICATIONS

ELECTRICAL SPECIFICATIONS

Family	INPUT CHARACTERISTICS			OUTPUT CHARACTERISTICS		
	Input Voltage	Power Factor	Max. Current	Max. Output Power	Rated Output Current	Output Voltage
5W	120-277Vac	≥ 0.5	0.051A @ 120V	5W	250mA-100mA	20~54Vdc

Emergency pack designed to deliver 5W to a constant current LED load. Approximate output is 500 lumens assuming a nominal minimum efficacy of 100lm/W.

PHYSICAL SPECIFICATIONS

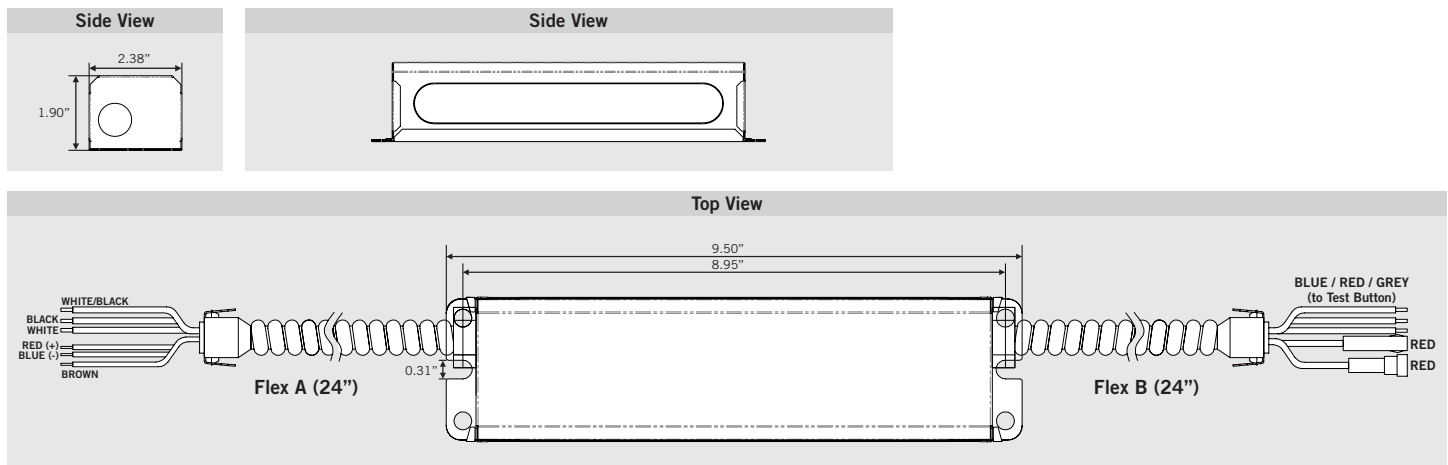



KT-EMRG-LED-5-500-EN /DF

CONSTANT WATTAGE LED EMERGENCY BACK-UP

WIRING DIAGRAM

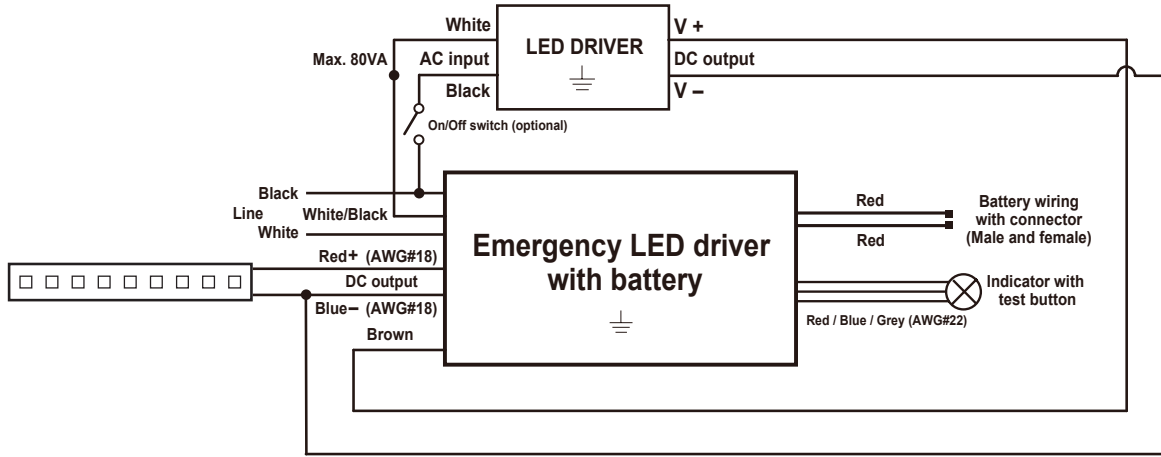

ORDERING INFORMATION

ORDER CODE	DESCRIPTION	PACKAGING STYLE	PACK QTY.	ITEM STATUS
KT-EMRG-LED-5-500-EN /DF-IP	1-Piece LED Emergency Back Up with Dual Flex Conduit	Individually Packaged	1	Active

ALTERNATIVE OPTIONS

ORDER CODE	DESCRIPTION	PACKAGING STYLE	PACK QTY.	ITEM STATUS
KT-EMRG-LED-5-500-EN /RJSF-IP	1-Piece LED Emergency Back Up with Rear Junction Leads and Single Flex Conduit (Flex B)	Individually Packaged	1	Custom Order
KT-EMRG-LED-5-500-EN-IP	1-Piece LED Emergency Back Up with Standard Wire Leads	Individually Packaged	1	Custom Order

CATALOG NUMBER BREAKDOWN

KT-EMRG-LED-5-500-EN /DF

